

Condair ME II

ERSATZTEILE / SPARE PARTS / PIECES DE RECHANGE

Änderungen vorbehalten! / Subject to change! / Modifications réservées!

Pos	Artikel/Article/Article	Zusatz/Completion/Complément	SAP-No.
Steuereinheit ME Control / ME Control control unit / Unité de commande ME Control			
100	Integrated controller mit Touchpanel (Steuerplatine) Integrated controller with touchpanel (Control board) Integrated controller avec touchpanel (Platine de commande)		2606335
101	Smart Card Smart Card Carte à puce		2584599
102	24 VDC Spannungsversorgung ME Control ME Control 24 VDC Power Supply Kit Alimentation 24 VDC ME Control		2600874
103	Schliessbolzen komplett Cotter pin complete Bouton de fermeture		2590984
104	Frontabdeckung Steuereinheit Front Cover Control Unit Couvercle frontale unité de commande		2606188
105	Ferritring teilbar Snap Ferrite Ferrites à clapet		2579744
106	Schalter Switch Interrupteur		2597161
107	Wandhalterungen Steuereinheit ME Control Wall supports control unit ME Control Supports muraux unité de commande ME Control		1201039
108	Netztrennschalter Electrical isolator Sectionneur		2564847
109	Sicherung 6.3AF (3 Stk.) Fuse 6.3AF (3 pcs) Fusible 6.3AF (3 pcs)		2606289
	Sicherung 10AT (3 Stk.) Fuse 10AT (3 pcs) Fusible 10AT (3 pcs)		2606290
110	ME Control Eingangsklemmsset ME Control Incoming Terminal Kit Kit de bornes d'entrée ME Control		2606362

Pos	Artikel/Article/Article	Zusatz/Completion/Complément	SAP-No.
111	ME Control UV- Anschlussklemmenset ME Control UV Terminal Set Kit de bornes UV ME Control		2606363
112	ME Control UL UV-Relais ME Control UL UV Relay Relais UV ME Control UL		2606364
113	WD AMX-1 Leitfähigkeits-Alarm WD AMX-1 Conductivity Alarm WD AMX-1 Alarms conductivité		1200471
114	Signalgeber Pumpenfehler Pump Fault Transducer Transducteur de défaut de pompe		2587313
115	Platine Leitfähigkeitsmessung LF Board Platine de conductivité		2579734
116	Betriebs- und Störungsfernmeldung Remote Operating and Fault Indication Télésignalisation d'exploitation et de dérangement		2603503
117	Netzfilter Mains Filter Filtre secteur		2579739
118	Verteilplatine ME ≤3MH Distribution board ME ≤3MH Platine de distribution ME ≤3MH	Systemhöhe ≤3000 mm (≤118") System height ≤3000 mm (≤118") Hauteur de système ≤3000 mm (≤118")	1201042
	Verteilplatine ME >3MH Distribution board ME >3MH Platine de distribution ME >3MH	Systemhöhe >3000 mm (>118") System height >3000 mm (>118") Hauteur de système >3000 mm (>118")	1201043
119	Treiberplatine Driver Board Platine pilote		2579733
120	Interne Hauptsicherung F1 Internal Mains Fuse F1 Fusible principale F1	230V / 6.3AT	2536025
121	Sicherung Spannungsversorgung F2 Fuse Voltage Supply F2 Fusible alimentation en courant F2	10/24VDC / 630 mA	2559408
122	Leckagemelder Leakage Detector Détecteur de fuites		2566935
123	Schutzabdeckung für F1/F2 Protecting Cap for Fuse F1/F2 Capots de protection pour fusible F1/F2		1201084
124	Montageset Treiberplatine Driver Board Mounting Kit Kit d'installation platine de pilotage		1201083
125	Gateway-Platine BACnet IP ME II Gateway Board BACnet IP ME II Platine passerelle BACnet IP ME II		2606233

Pos	Artikel/Article/Article	Zusatz/Completion/Complément	SAP-No.
	Gateway-Platine BACnet MS/TP ME II Gateway Board BACnet MS/TP ME II Platine passerelle BACnet MS/TP ME II		2606234
	Gateway-Platine Lonworks ME II Gateway Board Lonworks ME II Platine passerelle Lonworks ME II		2583808
126	Einschaltstrombegrenzer-Modul Inrush Limiter Module Module limiteur de courant		2605655
127	Verschluss-Clip Locking Clip Clip de verrouillage		2601040
n/a	Frostschutz-Nachrüstooption Freeze Protection Retrofit Option Retrofit en option de la protection contre le gel		2601613
n/a	Nachrüstooption Leitfähigkeitssensor Conductivity Sensor Retrofit Option Retrofit en option du capteur de conductivité		2601012

Steuereinheit Condair ME Direct Feed / Condair ME Direct Feed control unit / Unité de commande Condair ME Direct Feed

200	ME Direct Feed Netzteilset ME Direct Feed Power Supply Kit Unité de courant ME Direct Feed		1201044
201	Regelungsrelais Relay Controller Relais asservi		1200449
202	Timer-Relais Timer Relay Relais temporisateur		1200450
203	Nezfilter Mains Filter Filtre secteur		2579739
204	ME Direct Feed Türverschlusset ME Direct Feed Door Kit Kit serrure de porte ME Direct Feed		2584467
205	ME Direct Feed Licht- und Schalterset ME Direct Feed Light and Switch Kit ME Direct Feed Light & Switch Kit		1201045
206	Schalter Switch Interrupteur		2579742
207	On/Off Klemmense On/Off Terminal Kit Kit de bornes On/Off		1201047
208	ME Direct Feed Eingangsklemmense ME Direct Feed Incoming Terminal Kit Kit de bornes d'entrée ME Direct Feed		1201046

Pos	Artikel/Article/Article	Zusatz/Completion/Complément	SAP-No.
209	Gehäuse kpl. ME Direct Feed ME Direct Feed housing assembly Boîtier cpl. ME Direct Feed		2596455
210	Frontabdeckung Steuereinheit ME Direct Feed Front Cover Control Unit ME Direct Feed Couvercle frontale unité de commande ME Direct Feed		2596114
Hydraulikmodul ME Control / ME Control hydraulic module / Module d'hydraulique ME Control			
300	Entlüfterdichtung Aerator Seal Joint d'aérateur		1200263
301	Entlüfter Aerator Aérateur		1200269
302	Ablaufventil ME Serie ME Series Drain Valve Vanne de vidange série ME		1200276
303	Einlassventil ME Serie ME Series Inlet Valve Vanne d'admission série ME		1200277
304	Schraube Magnetventil Solenoid Valve Plate Screw Vis électrovanne		1200275
305	Stufenpumpe (Pumpe ME System mit O-Ring) Stage Pump (ME System Pump with O-Ring) Pompe de niveau (Système ME avec joint torique)	Systemhöhe ≤3000 mm (≤118") System height ≤3000 mm (≤118") Hauteur de système ≤3000 mm (≤118")	1200273
	XL Stufenpumpe (Pumpe ME System mit O-Ring) XL Stage Pump (ME System Pump with O-Ring) Pompe d'étage XL (Système ME avec joint torique)	Systemhöhe >3000 mm (>118") System height >3000 mm (>118") Hauteur de système >3000 mm (>118")	1200565
306	Wartungskit ME Pumpe ME Pump Service Kit Kit de maintenance pompe ME		1200710
307	Niveausensor Level Sensor Capteur à niveau		1200362
308	Leitfähigkeitssensor Lf-GT Conductivity Probe Lf-GT Capteur de conductivité Lf-GT		1201049
309	Leitfähigkeitssensorkabel Conductivity Probe Cable Câble capteur de conductivité		2578737
310	Kabelbaum 4 oder 5 Stufen Cable Harness 4 or 5 stages Faisceau de câbles 4 ou 5 étages	Systemhöhe ≤3000 mm (≤118") System height ≤3000 mm (≤118") Hauteur de système ≤3000 mm (≤118")	1200359
	Kabelbaum 4 oder 5 Stufen Cable Harness 4 or 5 stages Faisceau de câbles 4 ou 5 étages	Systemhöhe >3000 mm (>118") System height >3000 mm (>118") Hauteur de système >3000 mm (>118")	1200566

Pos	Artikel/Article/Article	Zusatz/Completion/Complément	SAP-No.
	Kabelbaum 2 oder 3 Stufen Cable Harness 2 or 3 stages Faisceau de câbles 2 ou 3 étages	Systemhöhe ≤3000 mm (≤118") System height ≤3000 mm (≤118") Hauteur de système ≤3000 mm (≤118")	1200567
	Kabelbaum 2 oder 3 Stufen Cable Harness 2 or 3 stages Faisceau de câbles 2 ou 3 étages	Systemhöhe >3000 mm (>118") System height >3000 mm (>118") Hauteur de système >3000 mm (>118")	1200568
311	Befestigungsschraube M4 Abdeckung ME Lid Captive Screw M4 Vis M4 Couvercle		1200274
312	Steckverbinder Push-Fit Connector Push-Fit	ø15 mm ø5/8"	1201089 1201090
313	O-Ring ME Verschlusszapfen ME Blanking Plug O-Ring Joint torique bouchon d'arrêt ME		1200270
314	O-Ringe Ablaufpumpenrohr (für FL4250) Pump Drain Tube O-Rings (for FL4250) Joint torique tube de la pompe vidange (for FL4250)		1200265
315	ME Ablaufrohr ME Drain Tube ME Tube de vidange		1200569
316	ME Ablaufanschlusset ME Drain Connector kit Kit de drainage ME	ø 32 mm ø 28 mm	1201026 1201028
317	ME Anschlussmuffe ME Connector spigot Douille d'accouplement ME	ø 54 mm ø 50 mm	1201027 1201025
318	UO Bodenlecksensor RO Floor Leakage Detection Sensor Capteur de fuite au sol OI		2580638
	Bodenlecksensor Floor Leakage Detection Sensor Capteur de fuite au sol		2597096
319	ME Hydraulikschlauch ME Hydraulic Hose ME tuyau hydraulique		1200264
320	Calfow-Ventil 12LPM Calfow Valve 12LPM Vanne Calfow 12LPM		2602726
321	Einlass-Schlauchadapter 1/2" - 15mm Inlet Stem Adaptor 1/2" - 15mm Adaptateur d'admission de tuyau 1/2" - 15mm		2605656
n/a	Austauschgehäuse Hydraulikmodul mit ø15 mm Anschlüssen Hydraulic Moulding Spare ø15 mm Boîtier de rechange module d'hydraulique avec raccords ø15 mm		1200708
n/a	Austauschgehäuse Hydraulikmodul mit ø5/8" (ø16 mm) Anschlüssen Hydraulic Moulding Spare Adpated ø5/8" (ø16 mm) Boîtier de rechange module d'hydraulique avec raccords ø5/8" (ø16 mm)		1200709

Pos	Artikel/Article/Article	Zusatz/Completion/Complément	SAP-No.
Hydraulikverteiler ME Direct Feed / ME Direct Feed hydraulic manifold / Distributeur d'hydraulique ME Direct Feed			
400	Befestigungsblech Direct Feed Direct Feed Bracket Fixing Plate Tôle de fixation Direct Feed		1200451
401	ME O-Ring 13.1mm x 1.6mmID ME O-Ring 13.1mm x 1.6mmID Joint torique ME 13.1mm x 1.6mm DI		1200272
402	Durchflussbegrenzer Spülventil 1 l/min weiss/pink Purge Valve Flow Restrictor 1 l/min White/Pink Restricteur de flux vanne de rinçage 1 l/min blanc/rose		1200452
403	Durchflussbegrenzer Stufenanschluss Stage Port Flow Restrictor Restricteur de flux raccord d'étage	Gelb/Yellow/Jaune 0.5 l/m Pink/Pink/Rose 1.0 l/m Hellblau/light blue/Bleu clair 1.4 l/m Schwarz/Black/Noir 1.9 l/m Grün/Green/Vert 2.5 l/m Purpur/Purple/Pourpre 3.0 l/m Dunkelblau/Dark Blue/Bleu foncé 3.5 l/m Rot/Red/Rouge 5.0 l/m Weiss/White/Blanc 8.0 l/m	1200673 1200674 1200675 1200676 1200677 1200678 1200679 1200680 1200681
404	Zulauf-/Spülventil Inlet/Purge Valve Vanne d'admission/de rinçage		1200570
405	Stufen-/Ablaufventil Stage/Drain Valve Vanne d'étage/d'écoulement		1200571
406	Verbindungsrohr 80 mm Connecting pipe 80 mm Tuyau de raccordement 80 mm	ø15 mm ø16 mm	1201075 1201076
407	ME Direct Feed Hydraulikverteiler ME Direct Feed Hydraulic Manifold ME Direct Feed distributeur hydraulique		1201077
408	Befestigungsset Hydraulikverteiler ME Direct Feed Mounting Set Hydraulic Manifold ME Direct Feed Kit de montage distributeur hydraulique ME Direct Feed		1201081
409	ME DF Adapter Hydraulikverteiler ME DF Manifold Adaptor with O-ring Adaptateur ME DF distributeur hydraulique	ø15 mm ø5/8"	2597496 2597498
410	ME DF Retrofit Zulauf- & Spülventil ME DF Retrofit Inlet & Drain Valve Set Kit de rééquipement ME DF vanne d'admission & vanne de rinçage	ø15 mm ø16 mm	2605624 2605625
411	ME DF Nachrüstset Spülventil ME DF Retrofit Purge Valve Kit Kit de rééquipement ME DF vanne de rinçage	ø15 mm ø16 mm	2605626 2605627

Pos	Artikel/Article/Article	Zusatz/Completion/Complément	SAP-No.
Verdunsterkassetten / Evaporative cassettes / Cassettes d'évaporation			
500	Support Tropfenabscheider unten Droplet Separator Bracket Bottom Support de séparateur du dessous		1200278
501	Halterung Tropfenabscheider oben Droplet Separator Bracket Top Support de séparateur du dessus		1200279
502	ME Winkel-Steckkupplung ME Push-Fit Elbow ME raccord coudé enfichable	ø15 mm ø5/8"	1200271 2597555
503	Matrix Verdunsterkassette - Fiberglas (BxHxT in mm) Evaporative Matrix Cassette - Glas fibre (WxHxD in mm) Matrice cassettes d'évapor. - Fibre de verre (LxHxP in mm)	300 x 250 x 100 300 x 250 x 150 300 x 250 x 200 300 x 375 x 100 300 x 375 x 150 300 x 375 x 200 300 x 500 x 100 300 x 500 x 150 300 x 500 x 200 300 x 750 x 100 300 x 750 x 150 300 x 750 x 200 300 x 1000 x 100 300 x 1000 x 150 300 x 1000 x 200 450 x 250 x 100 450 x 250 x 150 450 x 250 x 200 450 x 375 x 100 450 x 375 x 150 450 x 375 x 200 450 x 500 x 100 450 x 500 x 150 450 x 500 x 200 450 x 750 x 100 450 x 750 x 150 450 x 750 x 200 450 x 1000 x 100 450 x 1000 x 150 450 x 1000 x 200 600 x 250 x 100 600 x 250 x 150 600 x 250 x 200 600 x 375 x 100 600 x 375 x 150 600 x 375 x 200 600 x 500 x 100 600 x 500 x 150 600 x 500 x 200 600 x 750 x 100 600 x 750 x 150 600 x 750 x 200 600 x 1000 x 100 600 x 1000 x 150 600 x 1000 x 200	1200280 1200281 1200282 1200285 1200286 1200287 1200290 1200291 1200292 1200295 1200296 1200297 1200300 1200301 1200302 1200303 1200304 1200305 1200308 1200309 1200310 1200313 1200314 1200315 1200318 1200319 1200320 1200323 1200324 1200325 1200326 1200327 1200328 1200331 1200332 1200333 1200336 1200337 1200338 1200341 1200342 1200343 1200346 1200347 1200348

Pos	Artikel/Article/Article	Zusatz/Completion/Complément	SAP-No.
n/a	Matrix Verdunsterkassette - Polyester (BxHxT in mm) Evaporative Matrix Cassette - Polyester (WxHxD in mm) Matrice cassettes d'évaporation - Polyester (LxHxP in mm)	300 x 250 x 200	1200283
		300 x 250 x 300	1200284
		300 x 375 x 200	1200288
		300 x 375 x 300	1200289
		300 x 410 x 200	2597231
		300 x 410 x 300	2597232
		300 x 500 x 200	1200293
		300 x 500 x 300	1200294
		300 x 750 x 200	1200298
		300 x 750 x 300	1200299
		450 x 250 x 200	1200306
		450 x 250 x 300	1200307
		450 x 375 x 200	1200311
		450 x 375 x 300	1200312
		450 x 500 x 200	1200316
		450 x 500 x 300	1200317
		450 x 750 x 200	1200321
		450 x 750 x 300	1200322
		600 x 250 x 200	1200329
		600 x 250 x 300	1200330
		600 x 375 x 200	1200334
		600 x 375 x 300	1200335
600 x 410 x 200	2597233		
600 x 410 x 300	2597234		
600 x 500 x 200	1200339		
600 x 500 x 300	1200340		
600 x 750 x 200	1200344		
600 x 750 x 300	1200345		
n/a	Matrix Verdunsterkassette - Cooling (BxHxT in mm) Evaporative Matrix Cassette - Cooling (WxHxD in mm) Matrice cassettes d'évaporation - Cooling (LxHxP in mm)	300 x 250 x 200	1200667
		300 x 250 x 300	1200655
		300 x 368 x 200	2597235
		300 x 368 x 300	2597236
		300 x 375 x 200	1200666
		300 x 375 x 300	1200654
		300 x 500 x 200	1200665
		300 x 500 x 300	1200653
		300 x 750 x 200	1200664
		300 x 750 x 300	1200652
		450 x 250 x 200	1200663
		450 x 250 x 300	1200651
		450 x 375 x 200	1200662
		450 x 375 x 300	1200650
		450 x 500 x 200	1200661
		450 x 500 x 300	1200649
		450 x 750 x 200	1200660
		450 x 750 x 300	1200648
		600 x 250 x 200	1200659
		600 x 250 x 300	1200647
		600 x 368 x 200	2597237
		600 x 368 x 300	2597238
		600 x 375 x 200	1200658
		600 x 375 x 300	1200646
		600 x 500 x 200	1200657
		600 x 500 x 300	1200645
		600 x 750 x 200	1200656
		600 x 750 x 300	1200644

Pos	Artikel/Article/Article	Zusatz/Completion/Complément	SAP-No.		
504	ME Tropfenabscheiderkassetten - Fiberglas (BxH in mm) ME Droplet Seperator Cassette - Glass Fibre (WxH in mm) ME Cassettes de séparateur - Fibre de verre (LxH in mm)	300 x 250	1200349		
		300 x 375	1200350		
		300 x 500	1200351		
		450 x 250	1200352		
		450 x 375	1200353		
		450 x 500	1200354		
		600 x 250	1200355		
		600 x 375	1200356		
		600 x 500	1200357		
		n/a	ME Tropfenabscheiderkassetten - Polyester (BxH in mm) ME Droplet Seperator Cassette - Polyester (WxH in mm) ME Cassettes de séparateur - Polyester (LxH in mm)	300 x 250	1200462
				300 x 375	1200463
				300 x 500	1200464
450 x 250	1200465				
450 x 375	1200466				
450 x 500	1200467				
600 x 250	1200468				
600 x 375	1200469				
600 x 500	1200470				
505	Verteilkassette Distribution Cassette Cassette de distribution			300 x 100	1200572
				300 x 150	1200573
				300 x 200	1200574
		300 x 300	1200670		
		450 x 100	1200575		
		450 x 150	1200576		
		450 x 200	1200577		
		450 x 300	1200669		
		600 x 100	1200578		
		600 x 150	1200579		
		600 x 200	1200580		
		600 x 300	1200668		
506	Verteilhauben Distribution Head Tête de distribution	300x100mm - F	1201050		
		300x150mm - F	1201051		
		300x200mm - F	1201052		
		300x200mm - P	1201053		
		300x300mm - F	1201054		
		300x300mm - P	1201055		
		450x100mm - F	1201056		
		450x150mm - F	1201057		
		450x200mm - F	1201058		
		450x200mm - P	1201059		
		450x300mm - F	1201060		
		450x300mm - P	1201061		
		600x100mm - F	1201062		
		600x150mm - F	1201063		
		600x200mm - F	1200543		
		600x200mm - P	1201064		
		600x300mm - F	1201065		
		600x300mm - P	1201066		
		900x100mm - F	1200553		
		900x150mm - F	1201067		
		900x200mm - F	1201068		
		900x200mm - P	1201069		
		900x300mm - F	1201070		
		900x300mm - P	1201071		

Pos	Artikel/Article/Article	Zusatz/Completion/Complément	SAP-No.
507	Verteilhauben-Verschluss Distribution Head Clip Fermeture tête de distribution	Typ P / Type P / Type P	1201085
		Typ F / Type F / Type F	1201086
508	Anschlusstück Verteilhaube 16 mm Connection Piece Distribution Head 16 mm Piece de connexion tête de distribution 16 mm		1201082
509	Vertikaldichtung für ME System Upright Seal for ME System Joint vertical pour système ME	2 m Kit	1200364
		10 m Kit	2596823
510	Vertikaldichtung mit Aussparungen für ME System Upright Slotted Seal for ME System Joint vertical avec évidements pour système ME		1200365
511	Niete Rivet Rivet	20 Stk / 20 pcs / 20 pcs	2601212
512	Abdichtblech Blanking Plates Plaque d'étanchéité	30 x 60, l = 1250 mm	2595963
		40 x 70, l = 1250 mm	2595964
		50 x 80, l = 1250 mm	2595965
		40 x 105, l = 1250 mm	2600856
		40 x 130, l = 1250 mm	2595966
		40 x 155, l = 1250 mm	2600857
		40 x 195, l = 1250 mm	2600858
40 x 260, l = 1250 mm	2600859		
513	Schraubenset Abdichtblech Blanking Plate Screw Set Set de vis pour plaque d'étanchéité	20 Stk / 20 pcs / 20 pcs	2595967
514	Baugruppe Fallstange Drop Rod Assembly Assemblage de tige de descente		2600925
n/a	Befestigungsset für ME/MC Gestell stehend ME/MC Framework Upright Fixing Kit Kit de fixation pour montant du cadre ME/MC		2600923
n/a	Befestigungsset Erdungsbolzen Earth Stud Fixing Kit Kit de fixation du boulon de mise à la terre		2600924

Pos	Artikel/Article/Article	Zusatz/Completion/Complément	SAP-No.
Eintauch UV-System / Submerged UV system / Système UV immergé			
600	Austausch UV Modul Eintauch UV-System Sub UV Replacement UV Lamp Module Module de remplacement UV système UV immergé		1200369
601	ME Austausch UV Lampenclip ME Sub UV Lamp Clip Spare ME Remplacement UV Clip pour lampe		2601208
602	ME Control CE Austausch UV Stromverteilerkasten ME Control CE Submerged UV Power Distribution Box ME Control CE Remplacement boîte de distribution d'électricité UV	1 Lampe/Lamp/Lampe - 230VAC 1 Lampe/Lamp/Lampe - 110VAC 2 Lampen/Lamps/Lampes - 230VAC 2 Lampen/Lamps/Lampes - 110VAC 3 Lampen/Lamps/Lampes - 230VAC 3 Lampen/Lamps/Lampes - 110VAC 4 Lampen/Lamps/Lampes - 230VAC 4 Lampen/Lamps/Lampes - 110VAC	2598789 2602955 2598790 2602956 2598791 2602957 2598793 2602958
603	Austausch UV Vorschaltgerät CE Sub UV replacement Ballast CE Remplacement ballast UV CE	CE Version - 230VAC CE Version - 110VAC	2598755 2599976
604	ME Control UL Austausch UV Stromverteilerkasten ME Control UL Submerged UV Power Distribution Box ME Control UL Remplacement boîte de distribution d'électricité UV	1 Lampe/Lamp/Lampe 2 Lampen/Lamps/Lampes 3 Lampen/Lamps/Lampes 4 Lampen/Lamps/Lampes	2603119 2603120 2603121 2603122
605	Austausch UV Vorschaltgerät UL Sub UV replacement Ballast UL Remplacement ballast UV UL	UL Version	2604220
606	UL Austausch-Verriegelungseinrichtung UL Interlock Spare Remplacement dispositif de verrouillage UL		2604221
607	UL Austausch-Verriegelungsstück UL Interlock Actuator Key Spare Remplacement pièce de verrouillage UL		2604222
n/a	ME Control CE Modul UV-System 230VAC ME Control CE Submerged UV System 230VAC ME Control CE système UV submergé 230VAC	1 Lampe/Lamp/Lampe 2 Lampen/Lamps/Lampes 3 Lampen/Lamps/Lampes 4 Lampen/Lamps/Lampes	1201087 1200367 1200368 1200893
n/a	ME Control UL Modul UV-System 110-230VAC ME Control UL Submerged UV System 110-230VAC ME Control UL système UV submergé 110-230VAC	1 Lampe/Lamp/Lampe 2 Lampen/Lamps/Lampes 3 Lampen/Lamps/Lampes 4 Lampen/Lamps/Lampes	2605657 2605658 2605659 2605660

Pos	Artikel/Article/Article	Zusatz/Completion/Complément	SAP-No.
PureFlo			
700	Sedimentfilter 10" 5 Micron 10" 5 Micron Sediment Filter Filtre de sédiment 10" 5 Micron		1201080
701	PureFlo kpl. PureFlo Assembly PureFlo cpl.		2573358
702	PureFlo PureFlo PureFlo		2566450
703	Spezienschlüssel Spanner Clé spéciale		1200460
704	Filtergehäuse kpl. Filter housing cpl. Boîtier de filtre cpl.	weiss / white / blanc blau / blue / bleu	1200610 1201022
705	Anschlussstück 15mm kompatibel mit ½" BSPM Connector 15mm compatible with ½" BSPM Connecteur 15mm compatible avec ½" BSPM		1200208
706	Reduzierung ½" BSP M-F Kugelventil Reduction piece ½" BSP M-F ball valve Pièce de reduction ½" BSP M-F vanne à boisseau sphérique		1200044
707	Sechskant-Gewindenippel ½" BSPM Threaded hex connector ½" BSPM Raccord fileté par rétreint hexagonal ½" BSPM		2591366
708	Filter-Support kpl. Filter Support cpl. Support filtre cpl.		1201078
709	Selbstbohrschrauben s/s 10x ¾ Self tapping screws s/s 10x ¾ Vis autotaraudeuse s/s 10x ¾		1201079
n/a	Inline-UV D15 230V Inline-UV D15 230V Inline-UV D15 230V		1200895
n/a	Inline-UV D15 110V Inline-UV D15 110V Inline-UV D15 110V		1200896
n/a	Inline-UV D16 230V Inline-UV D16 230V Inline-UV D16 230V		1200897
n/a	Inline-UV D16 110V Inline-UV D16 110V Inline-UV D16 110V		1200898
n/a	PureFlo D16mm PureFlo D16mm PureFlo D16mm		1200899

Pos	Artikel/Article/Article	Zusatz/Completion/Complément	SAP-No.
Allgemeine Ersatzteile / General spares / Pièces de rechange générale			
n/a	Durchflussbegrenzer für Altecnic Calflow Ventil Flow Restrictor for Altecnic Calflow Valve Restricteur de flux pour vanne Altecnic Calflow		1200461
n/a	Install. Kit Basic Control Install. Kit Basic Control Install. Kit Basic Control		2595986
n/a	BIK Control Extern D15mm XL BIK Control Extern D15mm XL BIK Control Extern D15mm XL		2595988
n/a	BIK Control Extern D16mm XL BIK Control Extern D16mm XL BIK Control Extern D16mm XL		2595990
n/a	Install. Kit Basic Direct Feed Install. Kit Basic Direct Feed Install. Kit Basic Direct Feed		2595992
n/a	BIK Direct Feed Extern BIK Direct Feed Extern BIK Direct Feed Extern		2595993
n/a	BIK Direct Feed Extern XL BIK Direct Feed Extern XL BIK Direct Feed Extern XL		2595994
n/a	PA-Rohr ø15/12 x 25 m - PA12 (Rolle) PA tube ø15/12 x 25 m - PA12 (Roll) Tube PA ø15/12 x 25 m - PA12 (rouleau)		2595996
n/a	Schlauch AD5/8" x ID0.5" x 25 m - PA (Rolle) Tubing OD5/8" x ID0.5" x 25 m - PA (Roll) Schlauch AD5/8" x ID0.5" x 25 m - PA (rouleau)		2595997
n/a	Befestigungsbinder (5 Stk.) Cable Fastening Tie Clips (5 pcs) Attaches de câble (5 pcs)		2601309

Steuereinheit ME Control
ME Control control unit
Unité de commande ME Control

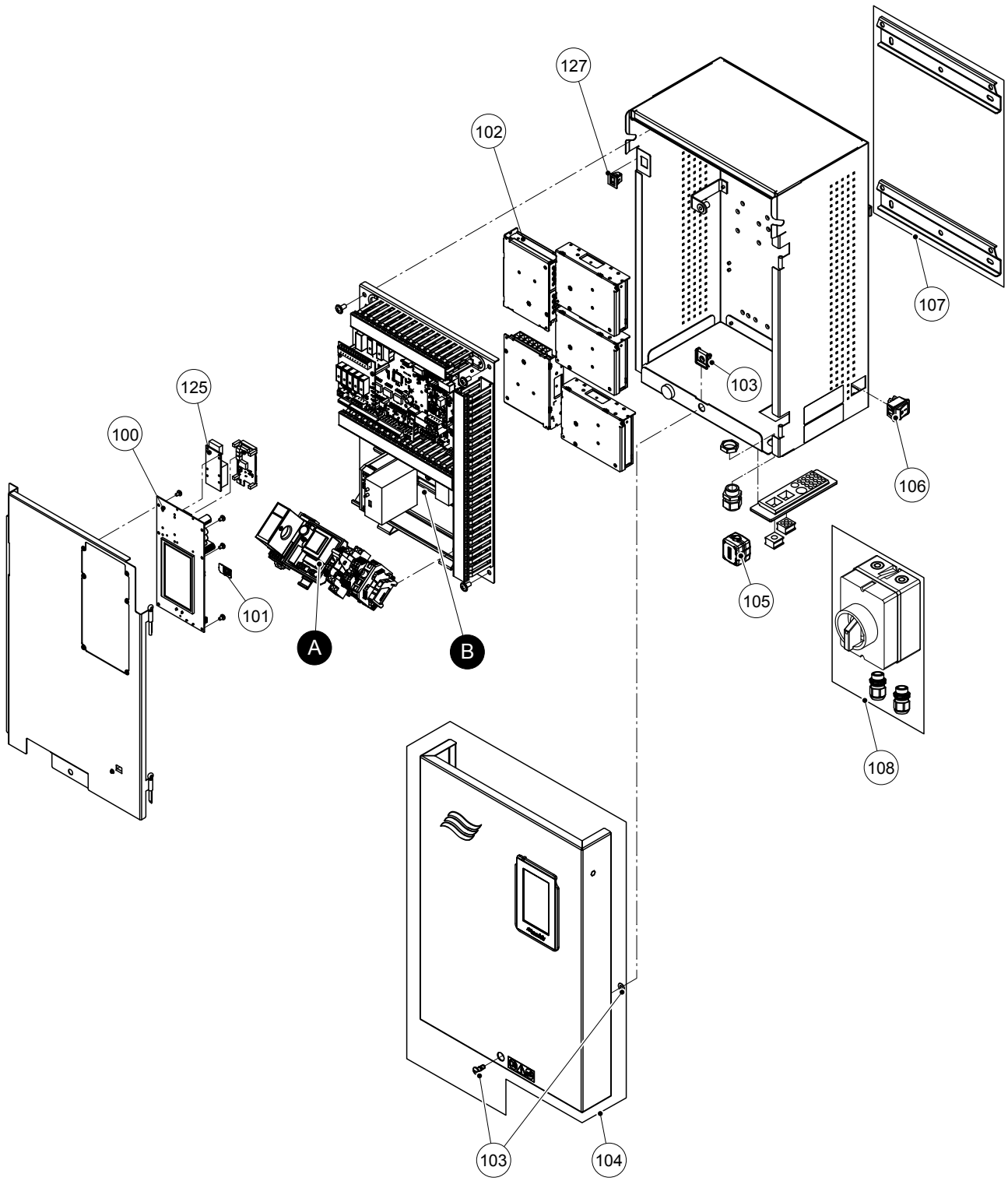

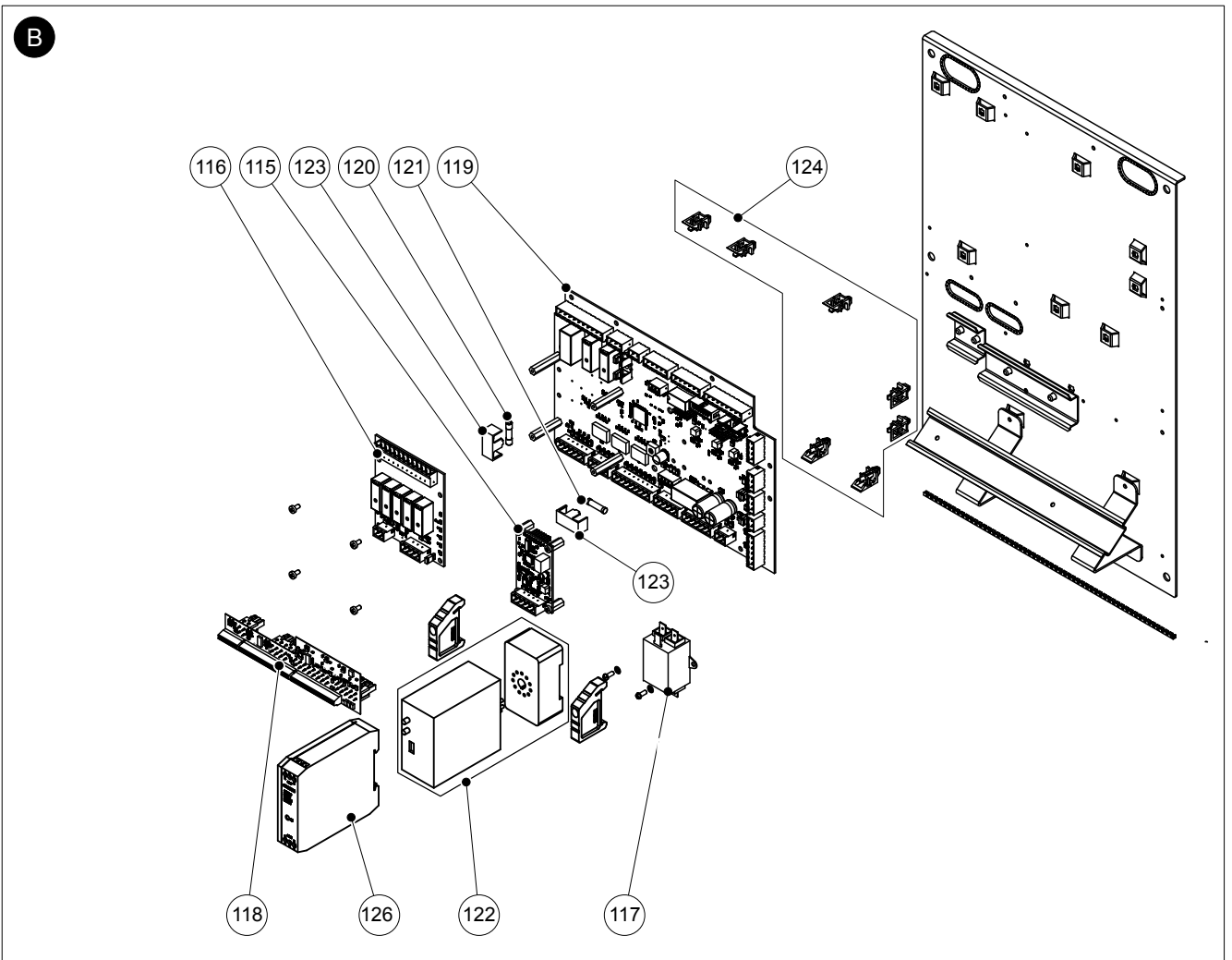
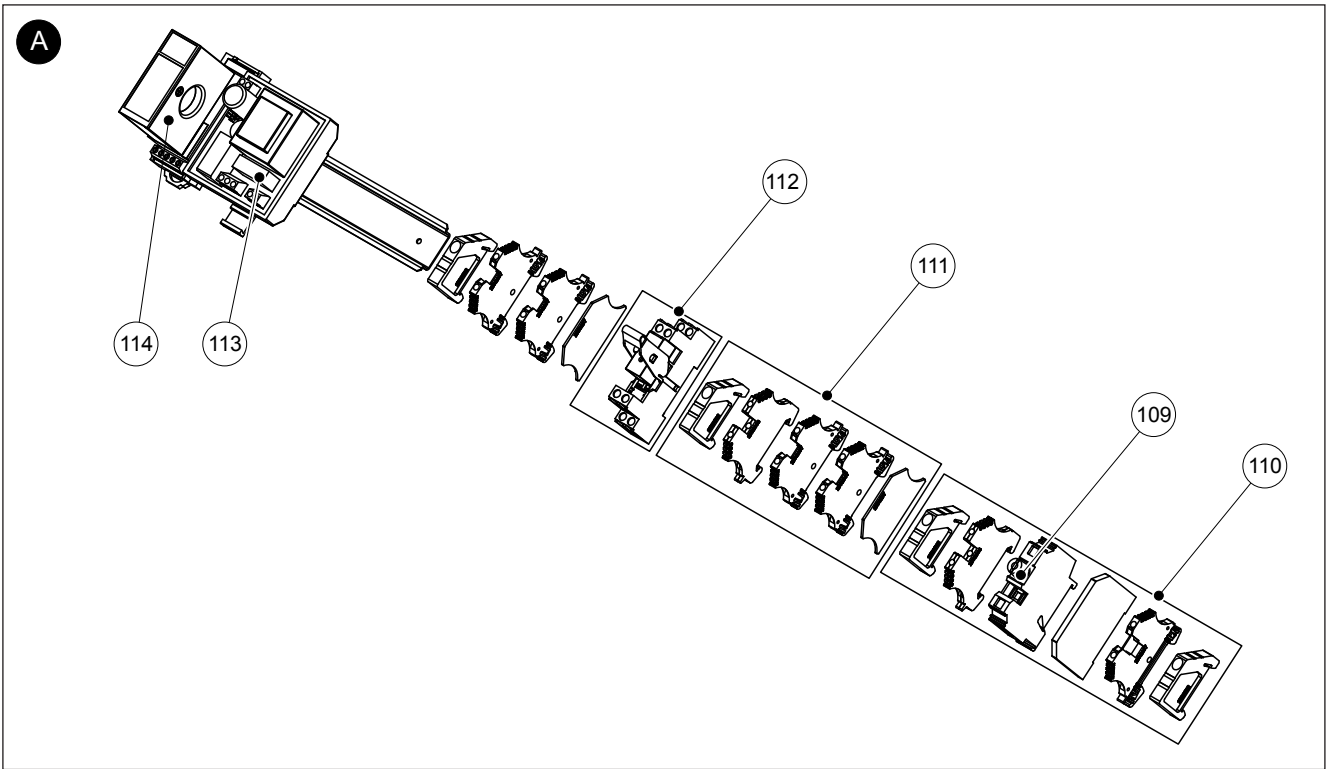

Steuereinheit Condair ME Direct Feed
 Condair ME Direct Feed control unit
 Unité de commande Condair ME Direct Feed

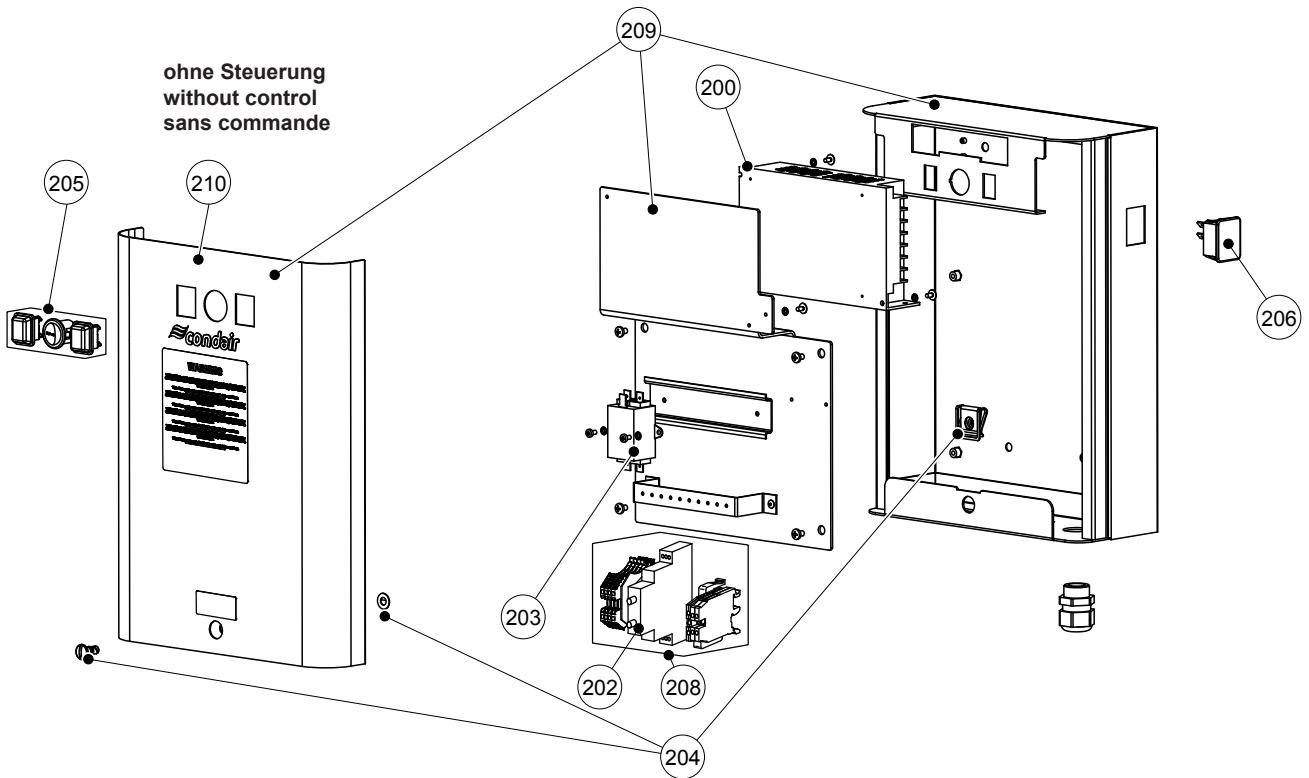
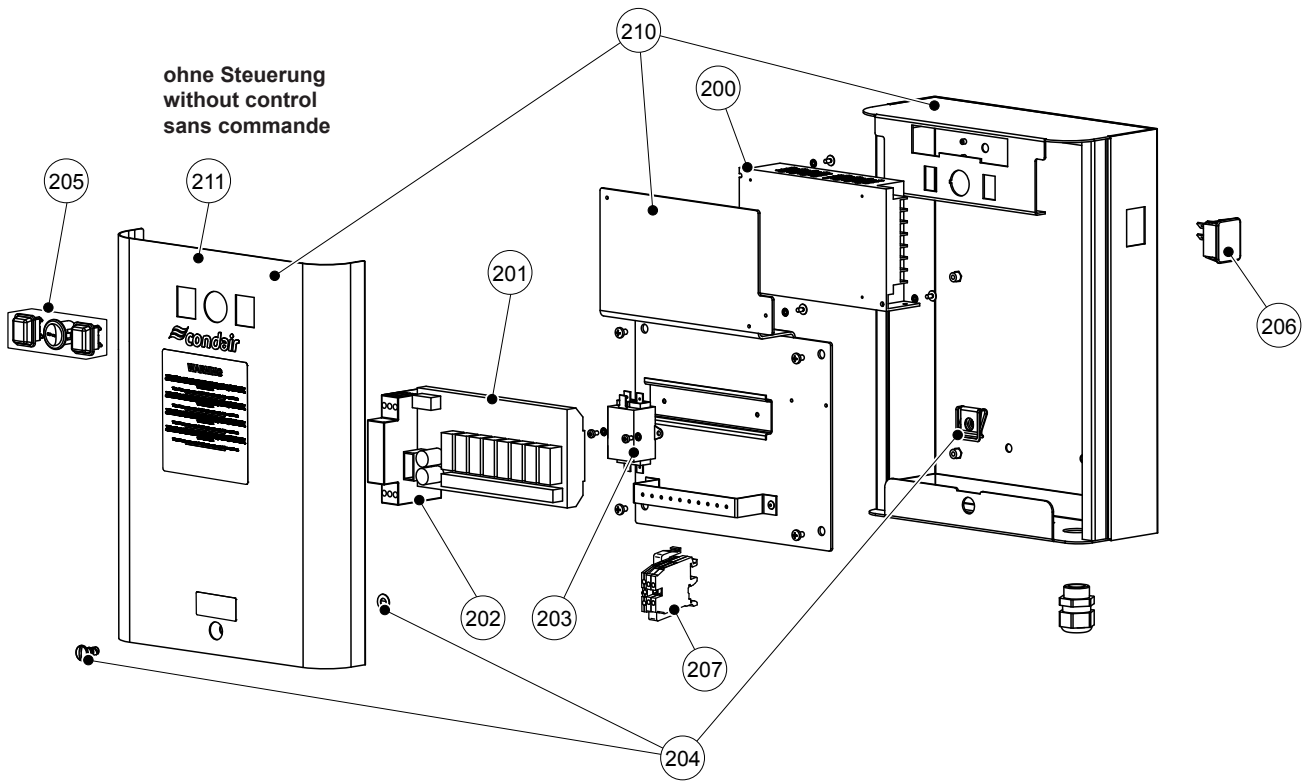

Hydraulikmodul ME Control
ME Control hydraulic module
Module d'hydraulique ME Control

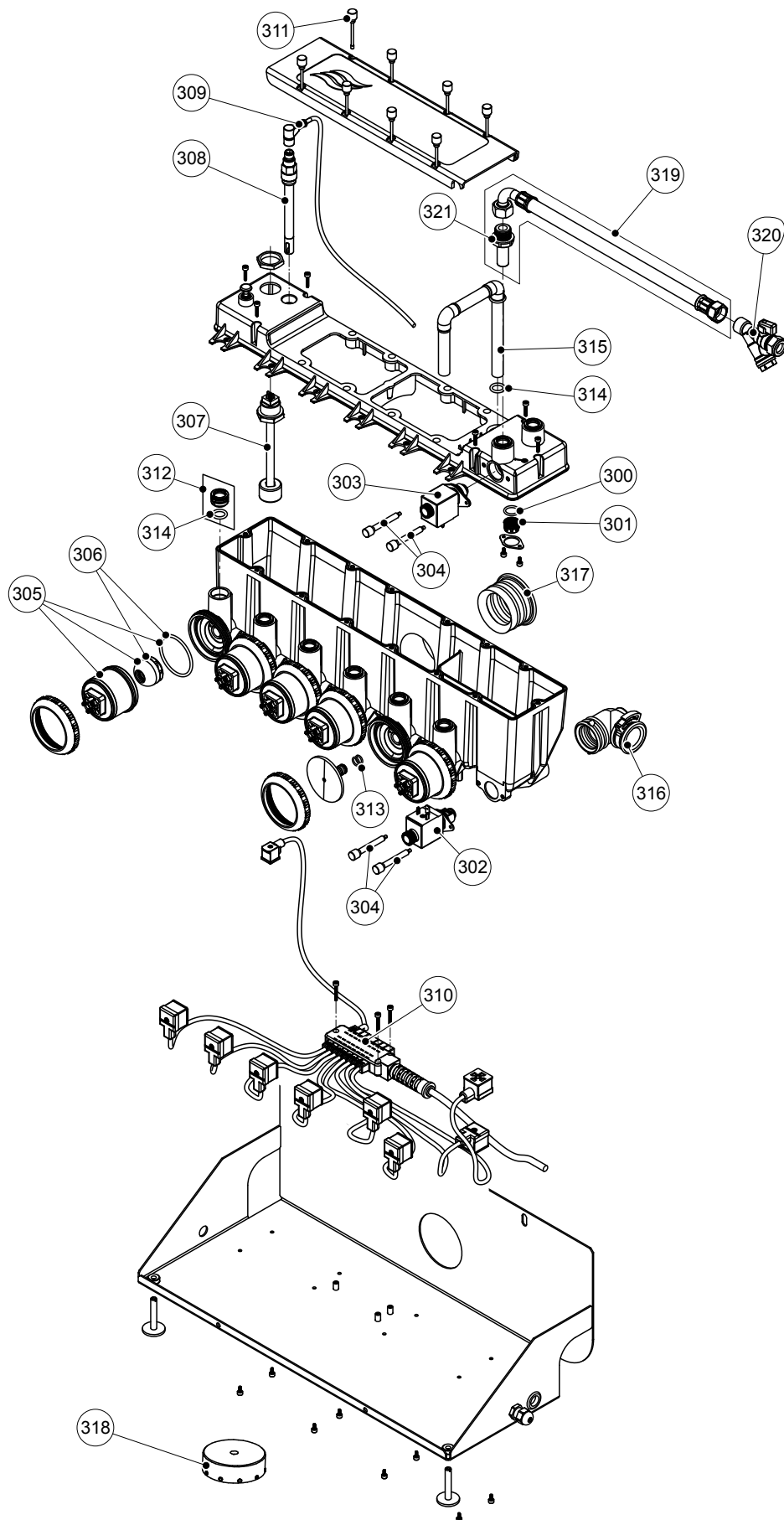

Hydraulikverteiler ME ME Direct Feed
ME ME Direct Feed hydraulic manifold
Collecteur d'hydraulique ME ME Direct Feed

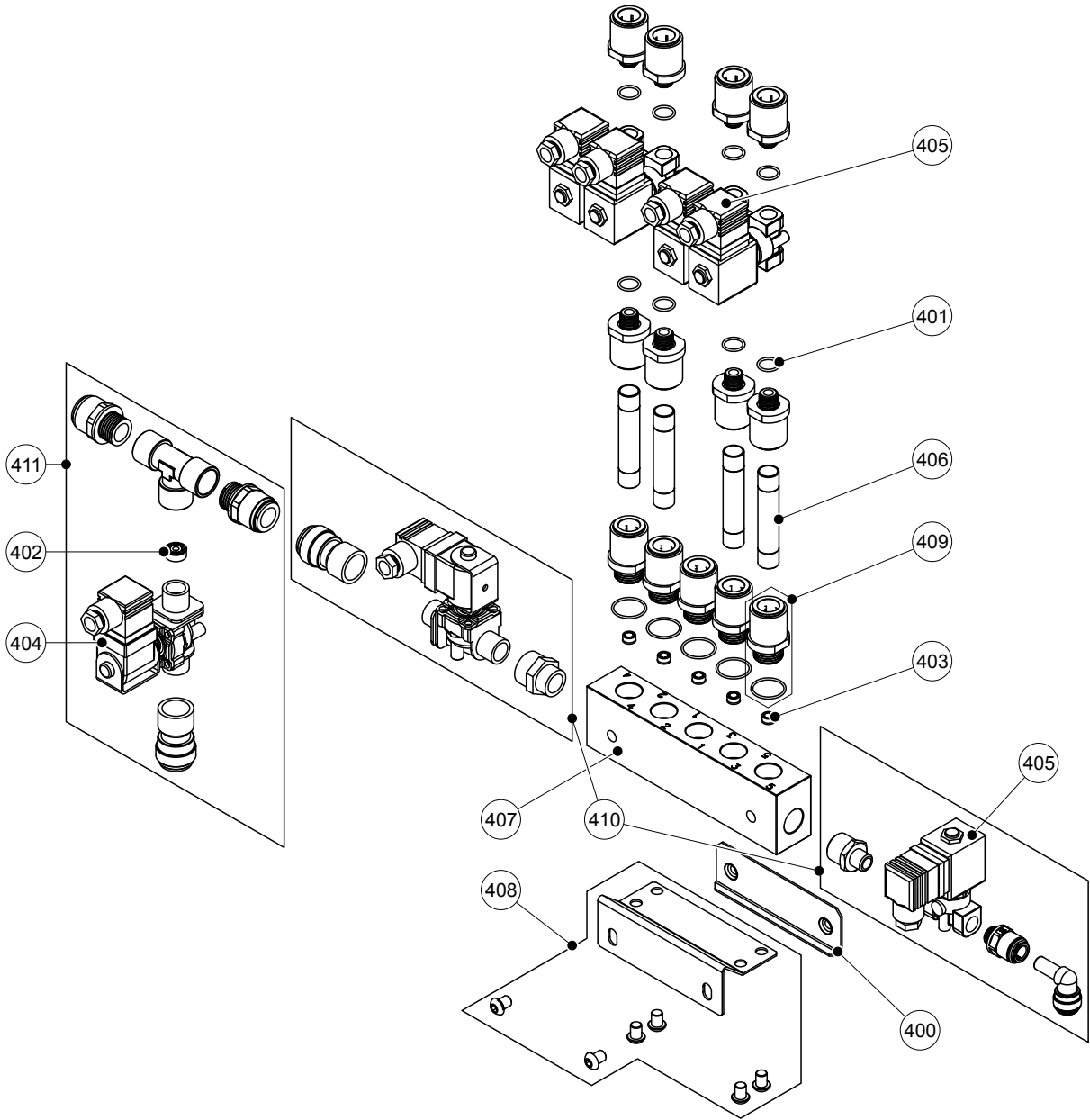

Verdunsterkassetten
Evaporative cassettes
Cassettes d'évaporation

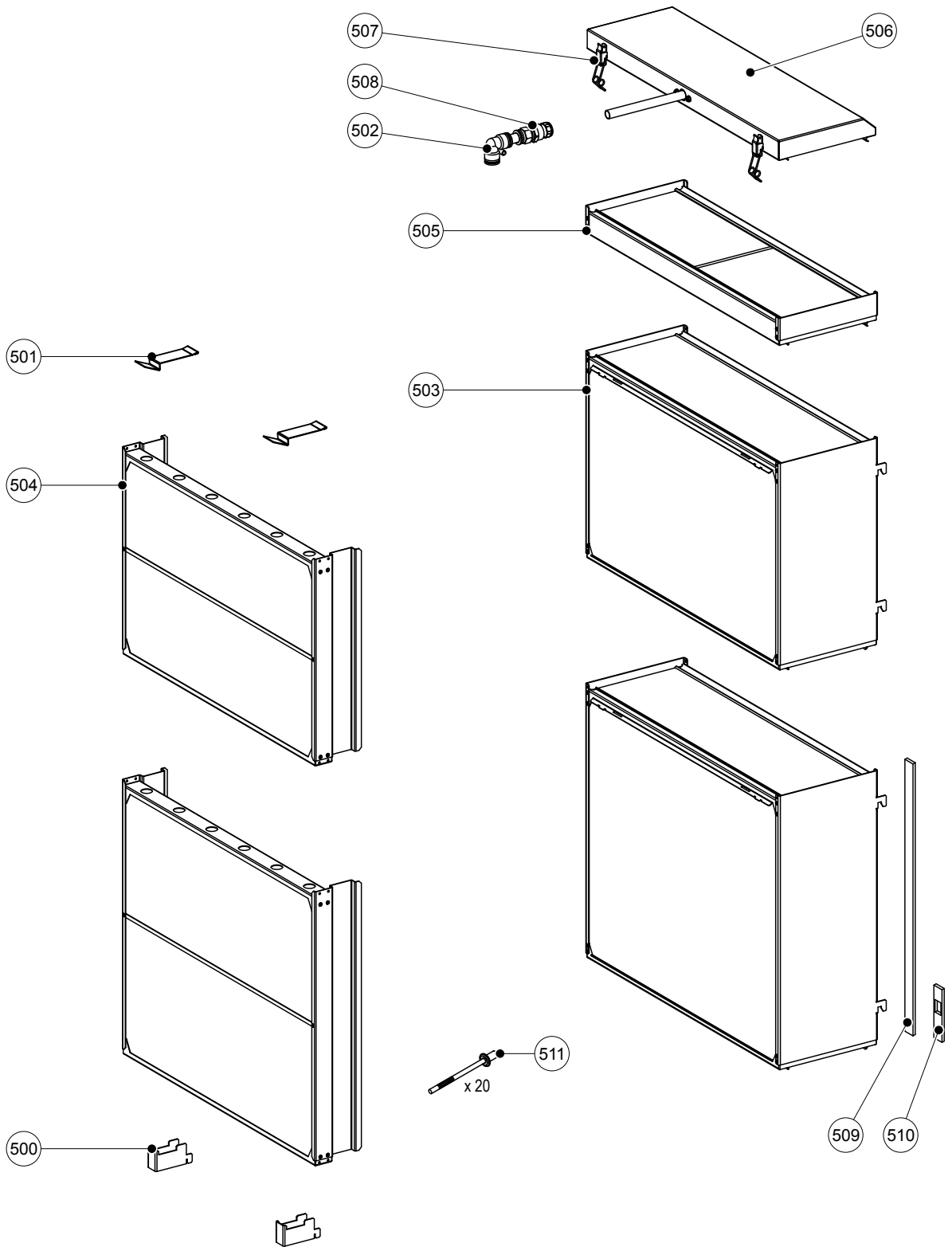

Rahmen Verdunstermodul
Frame Evaporative Module
Cadre module d'évaporation

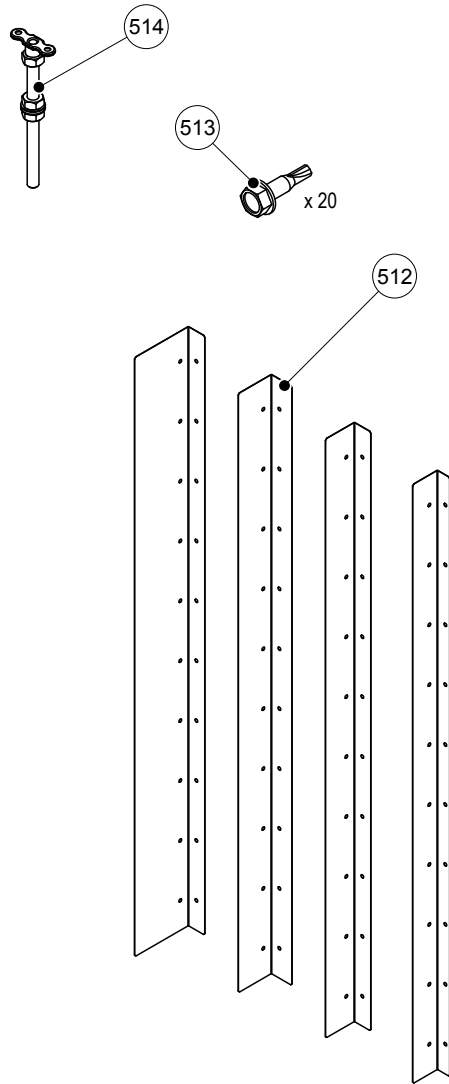
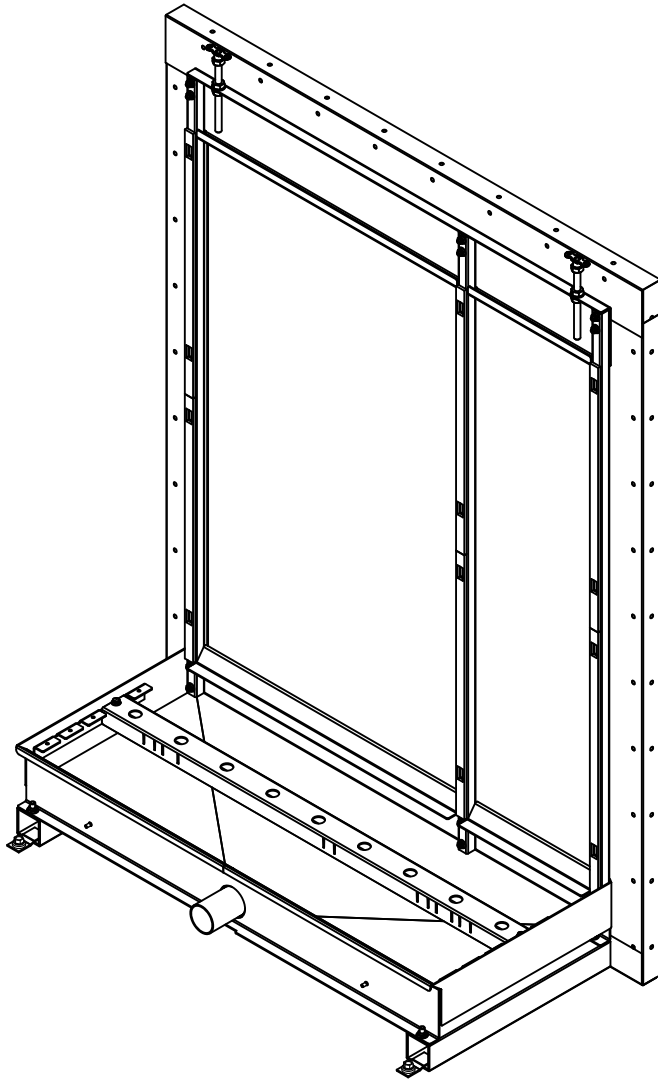

Eintauch UV-System
Submerged UV system
Système UV immergé

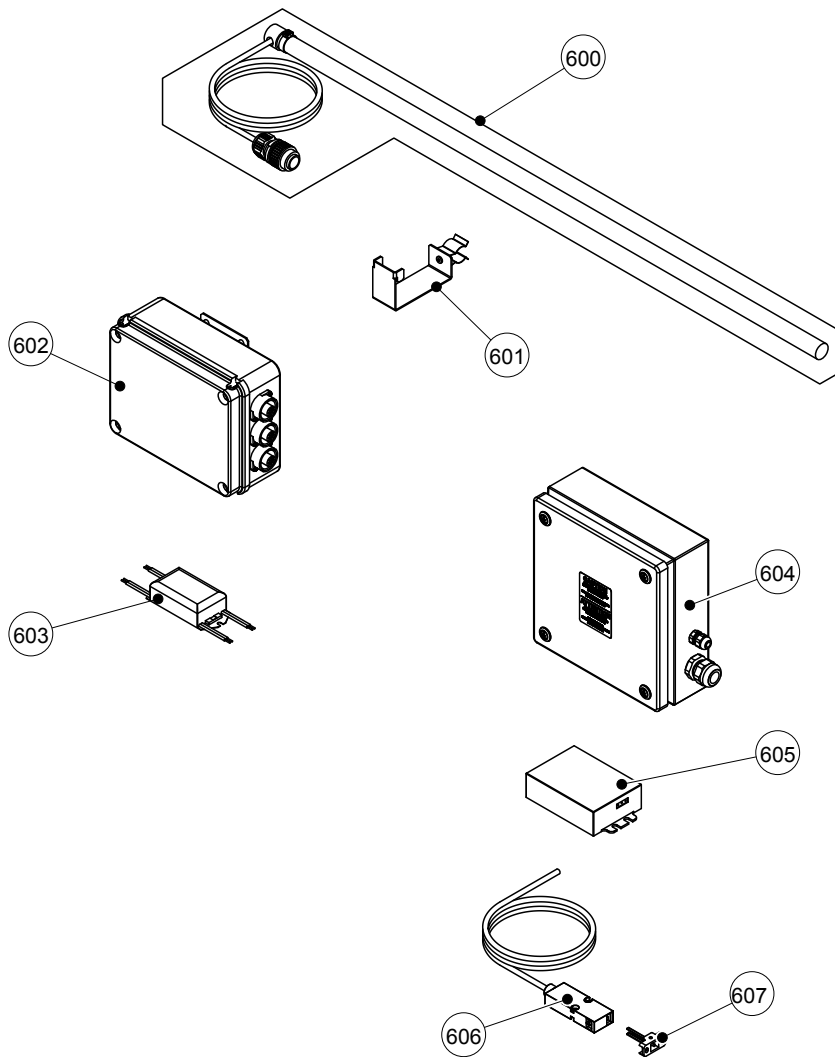

PureFlo

Durchflussrichtung (indikativ) ¹⁾
 Direction of flow (indicative) ¹⁾
 Sens d'écoulement (indicatif) ¹⁾

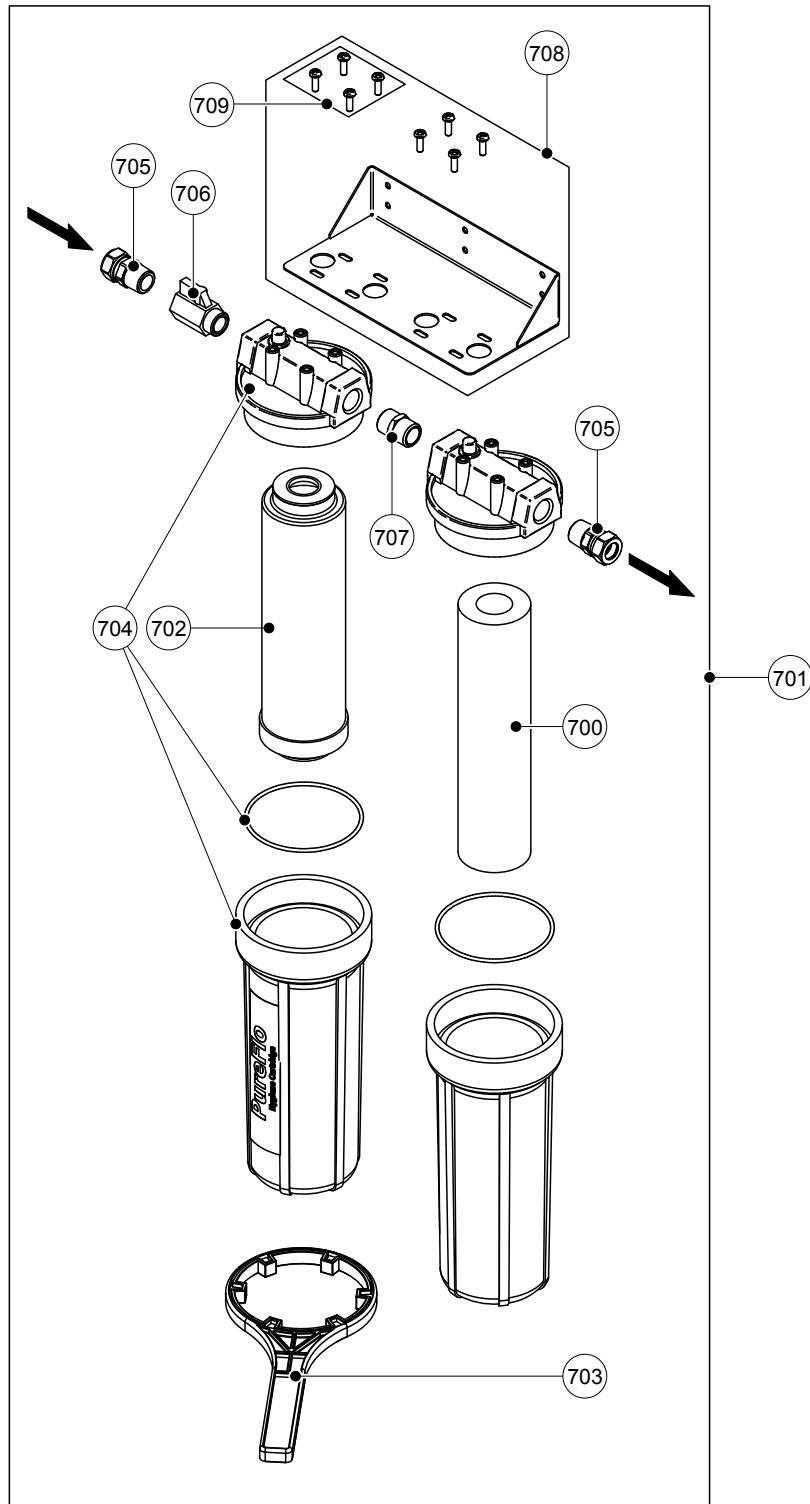

- ¹⁾ Die Gehäuseteile können am Halter 708 um 180° gedreht eingebaut werden, um die entgegengesetzte Durchflussrichtung beim Einbau zu berücksichtigen, Pos. 702 muss in Wasserflussrichtung immer vor Pos. 700 montiert werden.
 Housing components may be reversed on bracket 708 to suit opposite direction of flow in installation, item 702 must always be installed in front of item 700 in water flow.
 Les composants du boîtier peuvent être inversés sur le support 708 pour s'adapter au sens d'écoulement opposé lors de l'installation, l'élément 702 doit toujours être installé devant l'élément 700 dans le sens de flux d'eau.

CONSULTING, SALES AND SERVICE:



CH94/0002.00

Condair Group AG
Gwattstrasse 17, 8808 Pfäffikon SZ, Switzerland
Phone +41 55 416 61 11, Fax +41 55 588 00 07
info@condair.com, www.condairgroup.com

The Condair logo, consisting of a stylized wave symbol to the left of the word 'condair' in a bold, lowercase, sans-serif font.